



NAELCOM

2 Rue Jean Mermoz B.P.120
93297 Tremblay en France Cedex
FRANCE

Tel : +33 1 48 61 95 28

Fax : +33 1 48 61 94 03

e-mail : contact@naelcom.com

Web : www.naelcom.com

GPS RECEIVER NLC-iQ





LASSEN iQ IMPROVED REPLACEMENT GPS RECEIVER BOARD

The specifications in this document are subject to change without Notice. NAELCOM is not responsible for the operation or failure of operation of GPS satellites or the availability of GPS satellite signals.

BEST PERFORMANCE

NAELCOM has produced a new GPS receiver board, the "NLC-iQ", which is based on the Trimble Copernicus high performance GPS chip set. This OEM board is designed for use in embedded and industrial applications requiring high accuracy positioning and timing information. It can also be used as a replacement and upgrade for users of the Trimble Lassen iQ receiver board.

ADVANTAGES:

- Ultra-high sensitivity of **-160dBm** (-190dBw), enabling high performance acquisition and tracking in urban canyon and signal obscured environments.
- SBAS support (WAAS, EGNOS), for improved Horizontal and Altitude accuracy.
- Cold Start Time to First Fix (TTFF) is quicker than **38s**.
- Low power consumption: **37mA @ 3.3V** (without antenna).
- The 2 ports that can be configured to suit the customer's requirements such as: input and output protocols (TSIP, NMEA, TAIP) and transmission speed.
- Configuration parameters backed-up to an EEPROM.
- Pin to pin compatible with Trimble Lassen iQ GPS receiver; same form factor, for ease of integration.
- **Protection** against open and/or short circuit on the antenna, and alarms reported through serial port.
- Overvoltage protection on Antenna input.
- Accurate pps (pulse per second signal), better than **±60 ns**.
- New stationary mode for timing application.

SUMMARY OF THE CHARACTERISTICS:

Performances:

Receiver		12 channels
	Tracking sensitivity	-160dBm
	Acquisition Sensitivity (High "Indoor" Sensitivity Mode)	-148dBm*
	Acquisition Sensitivity (Standard Sensitivity Mode)**	-142 dBm
Initial acquisition time	Hot Start	3s
	Hot start w/o battery backup ***	8s
	Warm Start	35s
	Cold Start	38s
	Re-acquisition	2s
Accuracy	Horizontal @50% (@90%)	<2.5m (<5m)
	Horizontal with SBAS @50% (@90%)	<2.0m (<4m)
	Altitude @50% (@90%)	<5m (<8m)
	Altitude with SBAS @50% (@90%)	<3m (<5m)
	Velocity	0.06m/s
	PPS (Static)	± 60ns rms
	PPS (Stationary Mode "indoor" @ -145dBm)	± 350ns rms
	Receiver Dynamics Limit @ -144 dBm	2G****

* For Hot Start with ephemeris, otherwise -146dBm.

** Standard Acquisition Sensitivity is the default setting. High mode should be enabled for indoor applications.

*** Ephemeris is not older than 4 hours.

**** Receiver Dynamic Limit is 4G in open sky, Air Mode

Electrical characteristics

Prime power	Voltage	3.2 to 3.6 VDC
	Power consumption	50mA with active antenna
Antenna voltage		3 to 3.3 VDC

EMC compatibility

The NLC-iQ board has successfully completed compliance testing against the following standards listed below: (In accordance with the  directive).

- EN55022 class B (conducted and radiated emissions) dated January 1999, with 10dB margin.
- EN61000-4-3 published in 2002: "Immunity tests on electromagnetic fields radiated at radio-electrical frequencies", with 10V/m electromagnetic field.
- EN61000-4-6 published in February 1997: "Immunity tests on conducted interference, induced by radio-electrical fields".
- EN61000-4-4 (Immunity to rapid transients) dated June 1995, with 2kV transients.
- EN61000-4-2 (Immunity to electrostatic discharges) dated June 1995.

For Information:

The EN61000-4-3 standard is identical to the CEI 1000-4-3 standard and replaces ENV50140.

The EN61000-4-3 standard (see note A) is mentioned in the EN50082-generic standard for electrical and electronic equipment designed for use in industrial environments.

The NF EN61000-4-6 standard is identical to the CEI 1000-4-6 standard and replaces ENV50141. The EN61000-4-6 standard (see note B) is mentioned in the EN50082-2 generic standard for electrical and electronic equipment designed for use in industrial environments.

Connectors description

8 pin 1.27 mm male header:

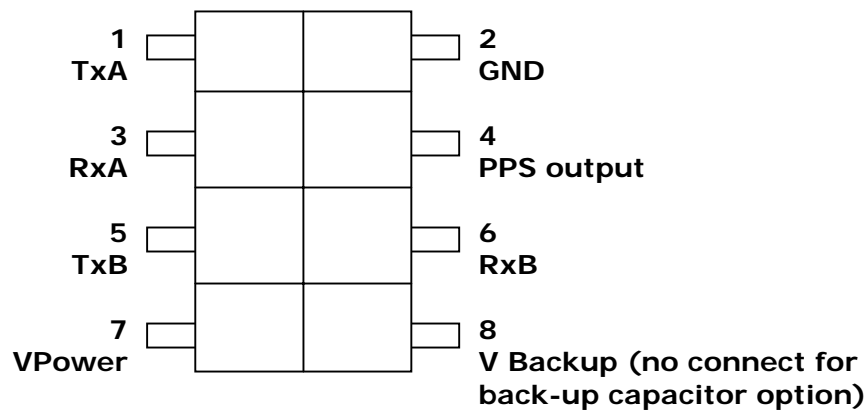

Antenna: Hirose HFL or transition cable to SMA.

Factory settings of the serial ports

The two communication ports (3.3V level) are set as standard as follows:

Port 1:

- Input: TSIP protocol, 38400 Baud, 8 bits, no parity, 1 stop bit.
- Output: TSIP protocol, 38400 Baud, 8 bits, no parity, 1 stop bit.

Port 2:

- Input: NMEA protocol, 4800 Baud, 8 bits, no parity, 1 stop bit.
- Output: NMEA protocol, 4800 Baud, 8 bits, no parity, 1 stop bit.

Ordering part number

The factory standard part number is NLC-IQ. However, customer can request several options, as described hereafter

NLC-IQ-XX

Option:

- Blank field : Straight fixing Pins (default)
- SP : without fixing Pin
- RA : Right angle fixing pins

NLC-IQ Module

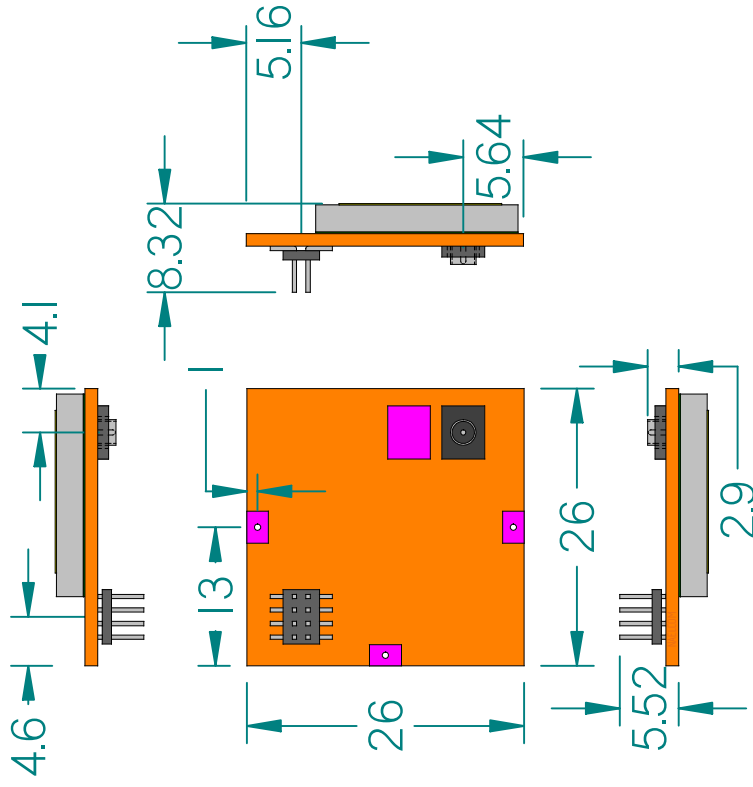

NLC-IQ Module

Straight Pins

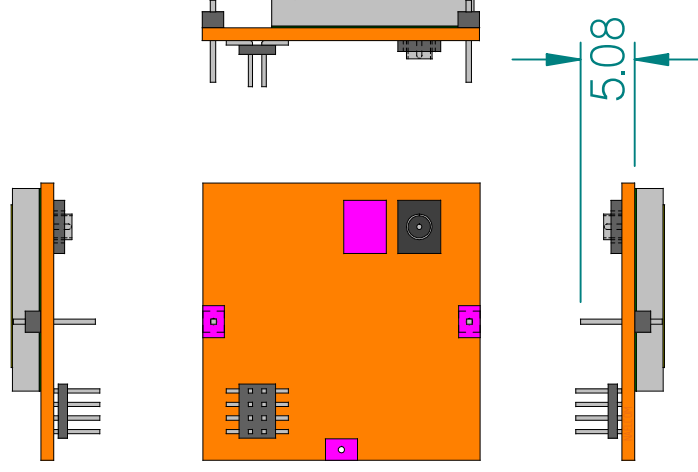

NLC-IQ Module

Right Angle Pins

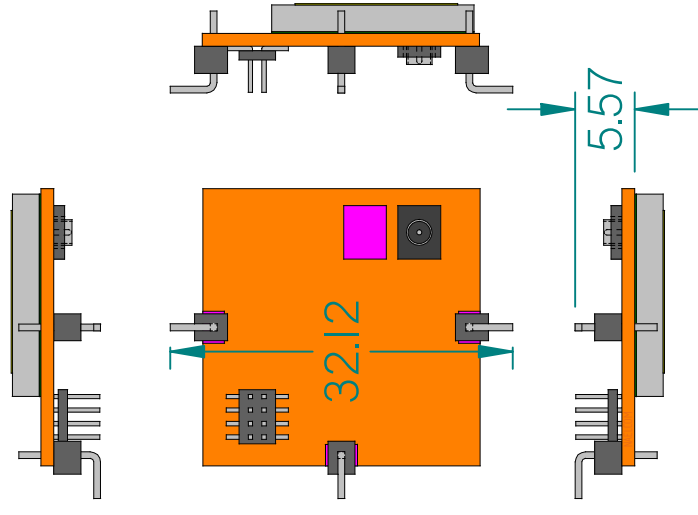

Note :



NLC-IQ Straight Pins

The height of the pins could be change on request.

NLC-IQ Right Angle Pins

Contact us for availability on this version.

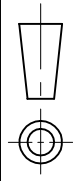
This document is the property of NAELCOM – Copy is not allowed without formal approval.

Material : NLC-IQ Module	Date : 29/01/2009	Drawing by : Luc GAUDIN	
Page : 1 / 1	Title : NLC-IQ module w/wo Pins		Rev. : V 1.01
	www.NAELCOM.com		
	Document name : NLC-IQ Plan EN.dft		